

# Watts Spacemaker®

SAFETY WATER HEATER  
INSTALLATION PRODUCTS

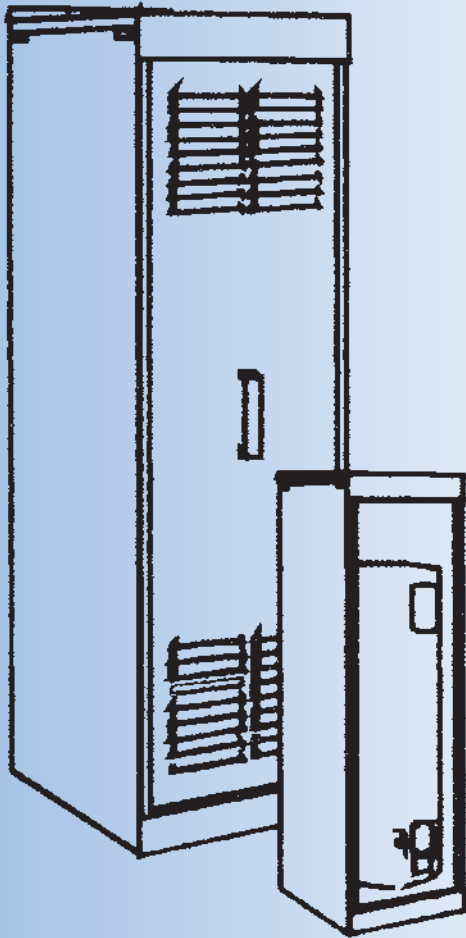

Enclosures

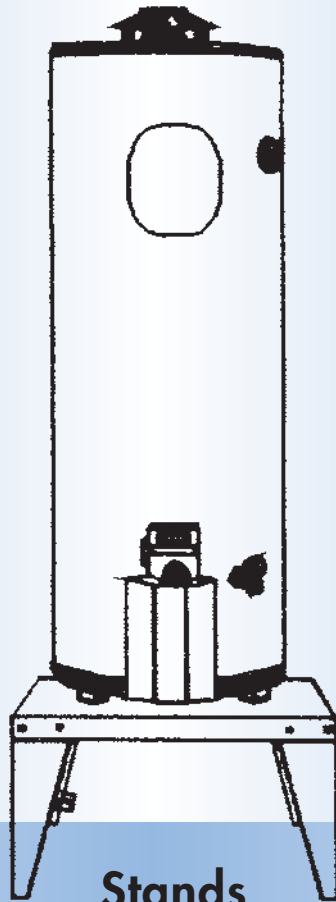

Stands

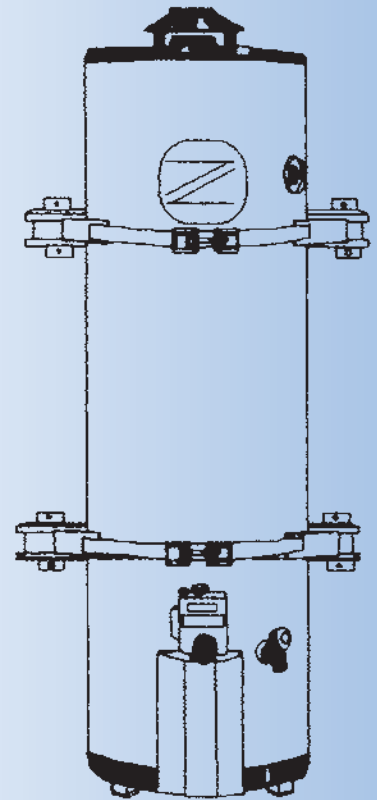

Restraints

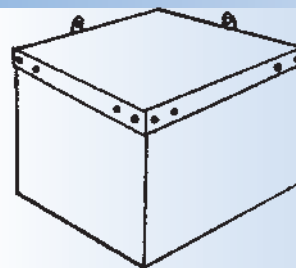
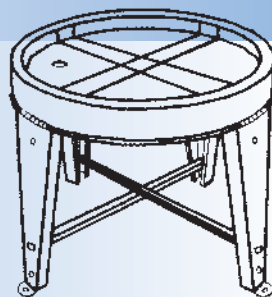

# WATTS Spacemaker

## TABLE OF CONTENTS / INTRODUCTION / SEISMIC ZONES

### Table of Contents

Seismic Zones / Introduction . . . . .	2
Outside Water Heater Enclosures . . . . .	3
Water Heater Stands . . . . .	4
Pre-assembled Stands	
Drip Pan Stand	
Enclosed Stand	
Water Heater Restraints . . . . .	5
Free Standing	
Wall Mounted	
Heavy-Duty Water Heater Restraints . . . . .	6
TSE-75 Straps	
E-75 Straps	
Water Heater Restraints . . . . .	7
Agent Listings . . . . .	8

### Introduction

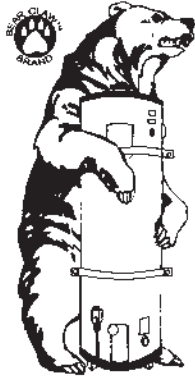

As part of our continuing commitment to the plumbing and heating industry to provide safety and code related items, such as Temperature and Pressure Safety Relief Valves, Backflow Prevention Devices and Thermostatic Mixing Valves, we have expanded our product offering to include Water Heater Installation Products.

Marketed under the name Spacemaker, the offering includes: Water Heater Straps and Restraints which are required by code in seismic zones 3 and 4; Water Heater Stands which raise the water heater flame element above the flammable vapors to reduce the risk of damage due to flame or explosion; and Water Heater Enclosures used to safely allow the water heater to be located out of the living area.

## UNITED STATES SEISMIC ZONES

 US AREAS IN SEISMIC ZONES 3 AND 4

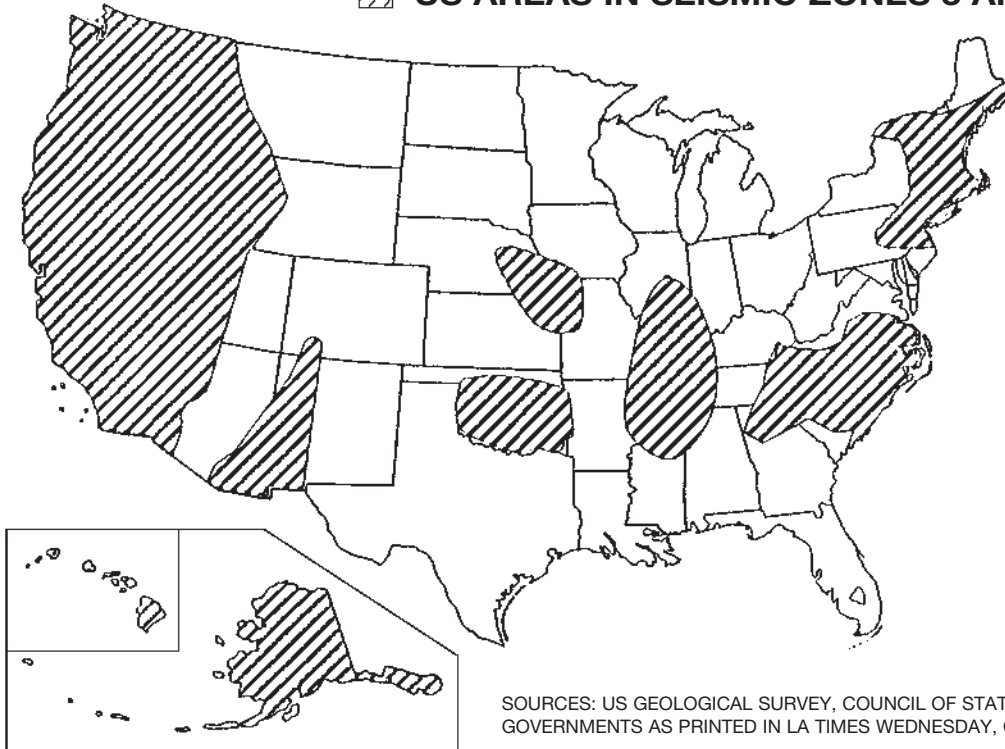

SOURCES: US GEOLOGICAL SURVEY, COUNCIL OF STATE GOVERNMENTS AS PRINTED IN LA TIMES WEDNESDAY, OCTOBER 5,

Where earthquake loads are applicable in accordance with the International Building Code, water heater supports shall be designed and installed for the seismic forces in accordance with the International Building Code.

Water heaters having an ignition source shall be elevated such that the source of ignition is not less than 18 inches (457mm) above garage floor.

# WATTS Spacemaker

## OUTSIDE WATER HEATER ENCLOSURES

### Outside Enclosures

These galvanized steel enclosures come three sided. Back sections are also available for every size. No nuts or bolts. Patent pending all clip-together design!

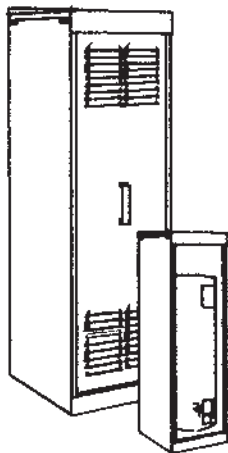

- Gain valuable space inside the home or garage - When space is at a premium, move the water heater outside with a Spacemaker outside water heater enclosure.
- Remove dangerous fire hazards from the home or garage - Move the water heater outside and protect it from the elements.
- Remove potential damage from a leaking water heater - A leaking water heater can damage floors, cabinets and structural members.
- Assembles in minutes with a hammer and pliers.
- No screws, nuts or bolts required.
- The Spacemaker outside water heater enclosure allows the water heater to be placed outdoors. This frees valuable space and removes dangerous fire hazards from the garage or home. These galvanized steel enclosures are three sided, however, back sections are available and sold separately. Watts Spacemaker enclosures are easily assembled using a unique clip-together design without the need for nuts or bolts.

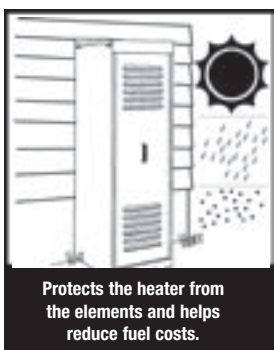

Protects the heater from the elements and helps reduce fuel costs.



Removes dangerous fire hazards from the garage and the home.

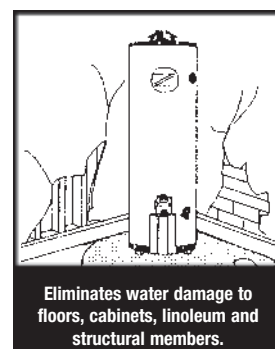

Eliminates water damage to floors, cabinets, linoleum and structural members.

Model Number	Ordering Code	For Water Heaters Tank (Gallons) Up To	Description and Size	Weight lbs. (each)
R-24 BL	0070001	20 - 50	24" Square x 72½" Tall Unassembled in carton	37
WPE-24(1)	0070006	20 - 50	24" Cabinet w/o Venting or Louvers	30
R-26 BL	0070002	20 - 65	26" Wide x 24" Deep x 72½" Tall Unassembled in carton	40
R-30 BL	0070004	50 - 80	30" Square x 72½" Tall Unassembled in carton	42
C-36 Com	0070005	80 - 100	36" Square x 82" Tall Unassembled in carton	94
B-24	0070007	—	24" Back Section for R-24BL Enclosures	12
B-24 WPE	0070011	—	Back Section for WPE-24	10
B-26	0070008	—	26" Back Section for R-26 Enclosures	13
B-30	0070009	—	30" Back Section for R-30BL Enclosures	14
B-36	0070010	—	36" Back Section for C-36 Enclosures	22

# WATTS Spacemaker

## WATER HEATER STANDS

### Pre-assembled Stands

Rugged galvanized steel stands come with floating seismic clips for easy installation.

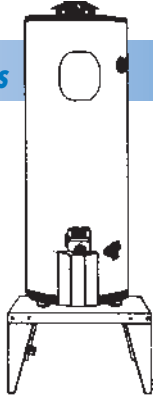

- Raises water heater flame element 18" above the floor. (as per Uniform Plumbing Code.)
- Reduces risk of fire, explosion, and property damage.
- Steel construction for safety and strength.
- Stand will not rot, melt, or burn.
- ICBO listed - ER-5172.

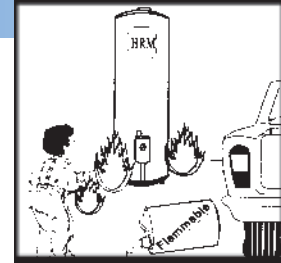

Thousands of fires are started every year by flammable vapors stored or used near a water heater or furnace.

### DPS-20 Drip Pan Stand

All clip together design with built-in drain pan and PVC drain connector. Used for water heaters up to 50 gallons.

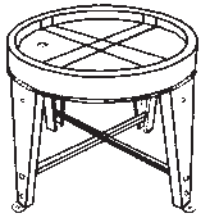

- Round stand includes built-in drip pan
- PVC drain connector
- Clip together design

Floating Seismic Clip for easy bolting to the wall.

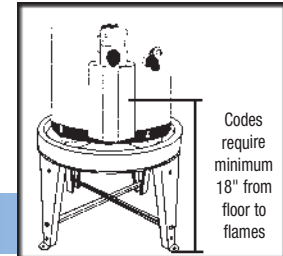
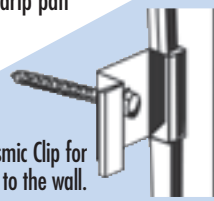

Codes require minimum 18" from floor to flames

### ENS-20 Enclosed Stand

Enclosed stand for use in food processing areas. Floating seismic clips for easy bolting to the wall.

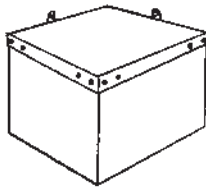

- For use in food processing areas.
- Fully enclosed on three sides to prevent storage of flammable liquids and/or hiding places for rodents.

Never store or use flammables within 50 feet of a water heater. Elevate the flame elements of the heater according to code to avoid flash fires.

Model Number	Ordering Code	For Water Heaters Tank (Gallons) Up To	Description	Size	Weight lbs. (each)
<b>PRE-ASSEMBLED STANDS</b>					
AS-20 *	0070012	52 gallons	Water Heater Stand	20" x 20" x 16"	11
AS-22 *	0070014	65 gallons	Water Heater Stand	22" x 22" x 16"	13
AS-26 *	0070016	75 gallons	Water Heater Stand	26" x 26" x 16"	14
AS-30 *	0070018	100 gallons	Water Heater Stand	30" x 30" x 16"	27
<b>DRIP PAN STAND (UNASSEMBLED)</b>					
DPS-20 *	0070020	52 gallons	Round Stand Unassembled in box with instructions.	16" x 22" **	12
<b>ENCLOSED STAND (UNASSEMBLED)</b>					
ENS-20 *	0070021	40 gallons	Enclosed Stand Unassembled in box with instructions.	20" x 20" x 16"	10
* Models include SEISMIC Clips to secure stand to the wall studs. Clips slide on the stand for easy adjustment to the wall stud dimensions.					
** Inner pan diameter 19 5/16"					
Note: AS-20 - Carton Quantity - 6, Pallet Quantity - 40					

# WATTS Spacemaker

## WATER HEATER RESTRAINTS

### Free Standing

Heavy duty angle iron frame complete with Spacemaker® E-100 restraints. Great for installations where no wall is available for mounting or where the walls are constructed out of metal studs.

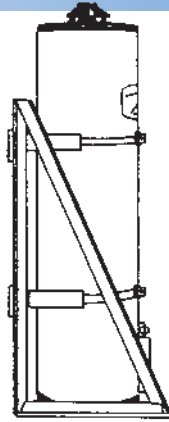

- Allows the safe placement of the water heater anywhere on roof or floor.
- Accommodates up to 100 gallon water heaters.
- Mounts to the roof or floor by bolting straight through or with the use of a floating clip.
- Features California state approved water heater safety straps.

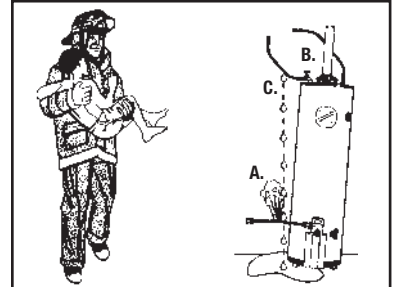

Even partially toppled water heater can cause dangerous gas, water, and exhaust leaks.

- A. Gas flex lines can crack.
- B. Flue pipes leak exhaust.
- C. Flex lines can separate and cause water leaks.

### Wall Mounted

Heavy-duty wall mount system includes E-100 restraints.

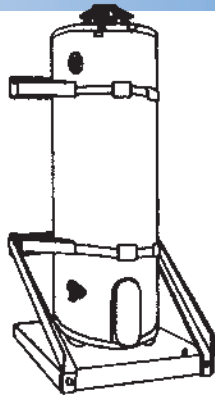

- Allows the safe placement of the water heater anywhere on a wall.
- Two sizes available for up to 120 gallon water heaters: 26" square pan and 30" square pan.
- Features California state approved water heater safety straps.
- Perfect for industrial applications

Model Number	Ordering Code	For Water Heaters Tank (Gallons) Up To	Description	Size	Weight lbs. (each)
<b>FREE STANDING WATER HEATER RESTRAINT SYSTEM</b>					
FS-26	0070022	65 gallons	Super heavy duty construction for installations where no wall is available for mounting.	Platform is 26" square.	56
FS-36	0070023	120 gallons	Super heavy duty construction for installation where no wall is available for mounting.	Platform is 36" square.	59
<b>Wall Mount Water Heater Restraint System</b>					
WM-26	0070024	65 gallons	Super heavy duty construction for installations against the wall where the water heater needs to be elevated.	Platform is 26" square.	45
WM-30	0070025	120 gallons	Super heavy duty construction for installations where the water heater needs to be elevated.	Platform is 30" square.	57

# WATTS Spacemaker

## HEAVY-DUTY WATER HEATER RESTRAINT

### Heavy-Duty Water Heater Restraint Systems

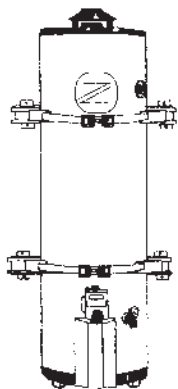

MODEL E100  
Shown on above

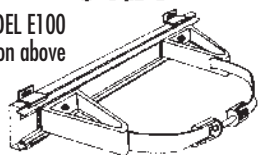

GLAA-PHCC endorses these restraints because of the extra value-added aspects.

- Use for optimal security.
- Cradles the tank with gussets for added security.
- Complies with all applicable codes.
- Fast convenient front tensioning of the restraint.
- Specially designed for cabinets and tight installations.

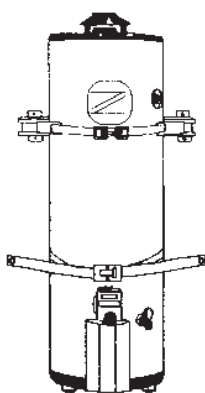

MODEL E50  
Shown above

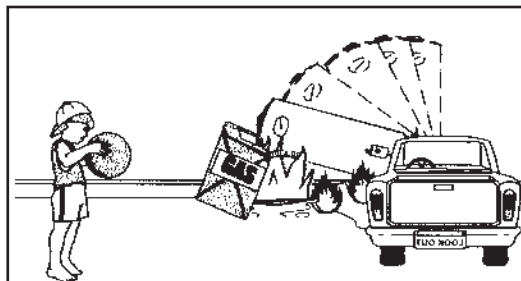

Thousands of fires are started every year by flammable vapors stored or used near a water heater or furnace.

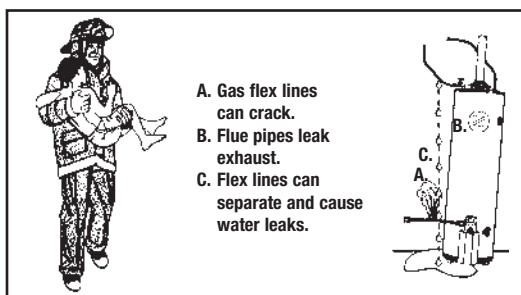

- A. Gas flex lines can crack.
- B. Flue pipes leak exhaust.
- C. Flex lines can separate and cause water leaks.

Even a partially toppled water heater can cause dangerous gas, water, and exhaust leaks.

Model Number	Ordering Code	For Water Heater Tank (Gallons) Up To	Description	Weight lbs. (each)
E-50	0070026	52 gallons	Double strapping system for tight spaces and/or cabinets where hardware needs to locate behind the water heater. Shake tested for up to 65 gallon water heaters. NOTE: Each kit contains a lower compliance strap that simply lags across the front of the tank.	7.5
E-100	0070028	100 gallons	Double strapping system for tight spaces and/or cabinets where hardware needs to locate behind the water heater. Shake tested for up to 100 gallon water heaters. Both upper and lower straps are as depicted above.	15

# WATTS Spacemaker

## WATER HEATER RESTRAINTS

### TSE-75 Water Heater Straps for zero clearance water heaters

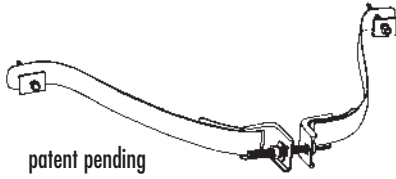

- Quick easy installation - Bolts directly into wall studs.
- Adjusts easily to fit water heater.
- Pre-assembled self tapping lag bolts.
- Kit contains four straps for restraining top and bottom of water heater.
- Lag bolts are pre-installed & held with paper keepers to prevent dropping behind the tank.

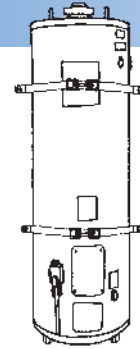

Simple across-the-front installation best used with zero clearance water heaters. Available in a box or a plastic bag.

Model Number	Ordering Code	For Water Heaters Tank (Gallons) Up To	Description	Weight lbs. (each)
TSE-75	0070029	75 gallons	Simple double straps for across-the-front installations. Unassembled in box with instructions.	3
TSE-75P	0070030	75 gallons	Simple double straps for across-the-front installations. No box. The straps are packaged in heavy duty polyolefin plastic shrink wrap.	3

### E-75 Water Heater Straps

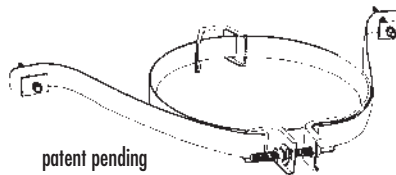

All straps are supplied with Lag Bolts with paper keepers

- Quick easy installation - Bolts directly into wall studs.
- Adjusts easily to fit water heater.
- Pre-assembled self tapping lag bolts.
- Kit contains four straps for restraining top and bottom of water heater.
- Includes back spacer to keep water heater from contact with the wall.
- Longer straps encircle the water heater or simply belt across the front.
- Lag bolts are pre-installed & held with paper keepers to prevent dropping behind the tank.

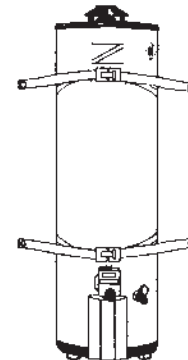

E-75 and the E-120 were tested and are approved for across-the-front installation or wrap around with our back spacers.

Model Number	Ordering Code	For Water Heaters Tank (Gallons) Up To	Description and Size	Weight lbs. (each)
E-75	0070031	75 gallons	The E-75 provides great flexibility in strapping the water heater. Each unit comes with complete instructions to either wrap the water heater with a non-flammable back spacer or strap across-the-front like the TSE-75. Unassembled in box with instructions.	4
E-120	0070032	120 gallons	The E-120 is the same as the E-75 except it comes with enough strap to encircle or go across the front of a 120 gallon water heater. Fully tested and approved by the California state architect. It is the best value for restraining a large water heater. Unassembled in box with instructions.	5



# For Technical Assistance Call Your Authorized Watts Agent.

			Telephone #	Fax #
	<b>HEADQUARTERS:</b> Watts Regulator Company	815 Chestnut St., North Andover, MA 01845-6098 U.S.A.	978 688-1811	978 794-1848
North East	Edwards, Platt & Deely, Inc.	277 Royal Ave., Hawthorne, NJ 07506	973 427-2898	973 427-4246
	Edwards, Platt & Deely, Inc.	368 Wyandanch Ave., North Babylon, NY 11703	631 253-0600	631 253-0303
	W. P. Haney Co., Inc.	51 Norfolk Ave., South Easton, MA 02375	508 238-2030	508 238-8353
Mid Atlantic	J. B. O'Connor Company, Inc.	P.O. Box 12927, Pittsburgh, PA 15241	724 745-5300	724 745-7420
	RMI	Glenfield Bus. Ctr., 2535 Mechanicsville Tpk., Richmond, VA 23223	804 643-7355	804 643-7380
	The Joyce Agency, Inc.	8442 Alban Rd., Springfield, VA 22150	703 866-3111	703 866-2332
	Vernon Bitzer Associates, Inc.	980 Thomas Drive, Warminster, PA 18974	215 443-7500	215 443-7573
	WMS Sales, Inc. (Main office)	9580 County Rd., Clarence Center, NY 14032	716 741-9575	716 741-4810
South East	Billingsley & Associates, Inc.	2728 Crestview Ave., Kenner, LA 70062-4829	504 602-8100	504 602-8106
	Billingsley & Associates, Inc.	478 Cheyenne Lane, Madison, MS 39110	601 856-7565	601 856-8390
	Francisco J. Ortiz & Co., Inc.	Charlyn Industrial Pk., Road 190 KM1.9 - Lot #8, Carolina, Puerto Rico 00983	787 769-0085	787 750-5120
	Mid-America Marketing, Inc.	203 Industrial Drive, Birmingham, AL 35211	205 879-3469	205 870-5027
	Mid-America Marketing, Inc.	1364 Foster Avenue, Nashville, TN 37210	615 259-9944	615 259-5111
	Mid-America Marketing, Inc.	5466 Old Hwy. 78, Memphis, TN 38118	800 365 6154	901 795-0394
	Smith & Stevenson Co., Inc.	4935 Chastain Ave., Charlotte, NC 28217	704 525-3388	704 525-6749
	Harry Warren, Inc.	1400 North Orange Blossom Trail, Orlando, FL 32804	407 841-9237	407 841-9246
	Watts Georgia	2861-B Bankers Industrial Drive, Atlanta, GA 30360	770 209-3310	770 447-4583
North Central	Dave Watson Associates	1325 West Beecher, Adrian, MI 49221	517 263-8988	517 263-2328
	Disney McLane & Associates	428 McGregor Ave., Cincinnati, OH 45206	800 542-1682	877 476-1682
	BWA Company	17610 S. Waterloo Rd., Cleveland, OH 44119	216 486-1010	216 486-2860
	Mid-Continent Marketing Services Ltd.	1724 Armitage Ct., Addison, IL 60101	630 953-1211	630 953-1067
	Soderholm & Associates, Inc.	7150 143rd Ave. N.W., Anoka, MN 55303	763 427-9635	763 427-5665
	Stickler & Associates	333 North 121 St., Milwaukee, WI 53226	414 771-0400	414 771-3607
South Central	Hugh M. Cunningham, Inc.	13755 Benchmark, Dallas, TX 75234	972 888-3808	972 888-3838
	HMC Sandia Group	13755 Benchmark, Dallas, TX 75234	505 222-3134	972 888-3838
	Mack McClain & Associates	4407 Meramec Bottom, Suite G, St. Louis, MO 63129	314 894-8188	314 894-8388
	Mack McClain & Associates, Inc.	1450 NE 69th Place, Ste. 56 Ankeny, IA 50021	515 288-0184	515 288-5049
	Mack McClain & Associates, Inc.	15090 West 116th St., Olathe, KS 66062	913 339-6677	913 339-9518
	OKI Sales, Inc.	214-A NE 12th., Moore, OK 73160	405 794-5200	405 794-5250
Western	Fanning & Associates, Inc.	6765 Franklin St., Denver, CO 80229-7111	303 289-4191	303 286-9069
	Hollabaugh Brothers & Associates	6915 South 194th St., Kent, WA 98032	253 867-5040	253 867-5055
	Hollabaugh Brothers & Associates	3028 S.E. 17th Ave., Portland, OR 97202	503 238-0313	503 235-2824
	P I R Sales, Inc.	3050 North San Marcos Place, Chandler, AZ 85225	480 892-6000	480 892-6096
	Preferred Sales	31177 Wiegman Road, Hayward, CA 94544	510 487-9755	510 476-1595
	R. E. Fitzpatrick Sales, Inc.	4109 West Nike Dr. (8250 South), West Jordan, UT 84088	801 282-0700	801 282-0600
Canada	Watts Industries (Canada) Inc. (Watts Regulator Co. Division)	5435 North Service Road, Burlington, Ontario L7L 5H7	905 332-4090	905 332-7068
	Con-Cur West Marketing, Inc.	71B Clipper Street, Coquitlam, British Columbia V3K 6X2	604 540-5088	604 540-5084
	D.C. Sales Ltd.	#10-6130 4th St. S.E., Calgary, Alberta T2H 2B6	403 253-6808	403 259-8331
	D.C. Sales Ltd.	16726 111 Ave, Edmonton, Alberta T5M 2S6	780 496-9495	780 496-9621
	GTA Sales Team.	Greater Toronto Area	888 208-8927	888 479-2887
	Hydro-Mechanical Sales, Ltd.	3700 Joseph Howe Drive, Suite 1, Halifax, Nova Scotia B3L 4H7	902 443-2274	902 443-2275
	Hydro-Mechanical Sales, Ltd.	P.O. Box 1445 (Mailing), 297 Collishaw St., Suite 7 (shipping) Moncton, New Brunswick E1C 9R2	506 859-1107	506 859-2424
	J.D.S. Sales Ltd.	4 Lancaster Street, St. John's, Newfoundland A1A 5P7	709 579-5771	709 579-1558
	Les Ent. Roland Lajoie	6221 Marivaux, St-Leonard, QC H1P 3H6	514 328-6645	514 328-6131
	Les Ent. Roland Lajoie	23 du Buisson, Pont Rouge, QC G3H 1X9	418 873-2500	418 873-2505
	Mar-Win Agencies, Ltd.	1333 Clifton St., Winnipeg, Manitoba R3E 2V1	204 775-8194	204 786-8016
	Northern Mechanical Sales	P.O. Box 280 (mailing) 163 Pine St. (shipping), Garson, Ontario P3L 1S6	705 693-2715	705 693-4394
	Palser Enterprises, Ltd.	P.O. Box 28136 (mailing), 1885 Blue Heron Dr., #4, London, Ontario N6H 5L9	519 471-9382	519 471-1049
RAM Mechanical Marketing Inc.	1401 St. John Street, Regina, Saskatchewan S4R 1S5	306 525-1986	306 525-0809	
RAM Mechanical Marketing Inc.	510 Ave M South, Saskatoon, Saskatchewan S7M 2K9	306 244-6622	306 244-0807	
Walmar Mechanical Sales	24 Gurdwara Rd., Nepean, Ontario K2E 8B5	613 225-9774	613 225-0673	
0801	<b>EXPORT Hdqtrs.:</b> Watts Regulator Co.	815 Chestnut St., North Andover, MA 01845-6098 U.S.A.	978 688-1811	978 794-1848



Water Safety & Flow Control Products



USA: 815 Chestnut St., No. Andover, MA 01845-6098; www.watts.com

Canada: 5435 North Service Rd., Burlington, ONT. L7L 5H7; www.wattscanada.ca