

For Commercial and Industrial Applications

Job Name _____

Contractor _____

Job Location _____

Approval _____

Engineer _____

Contractor's P.O. No. _____

Approval _____

Representative _____

Series C-FBV-1

2-Piece, Full Port, Carbon Steel Ball Valves

Sizes: 1/4" – 3" (8 – 80mm)

Series C-FBV-1 2-Piece, Full Port, Carbon Steel Ball Valves are suitable for a full range of liquids and gases. The C-FBV-1's full port orifice ensures maximum flow capacity, while reinforced PTFE seats, PTFE stem packing, thrust washer and body seal provide maximum safety and high operating pressure/temperature limits.



C-FBV-1

Features:

- Full port design
- Pressure rated at 1000psi (70 bars) WOG non-shock and 125psi (8.6 bars) WSP
- Adjustable stem packing
- Bottom loaded, blowout proof stem
- Drilled and tapped mounting pads
- PTFE stem packing, thrust washer and body seal
- Reinforced PTFE seat
- Vinyl insulator on heavy duty 304SS handles
- Low operating torque
- Each valve factory tested
- Standard Latch-Lok handle to lock in open or close position
- Conforms to MSS-SP-110 and API-598

Specifications

A 2-piece full port carbon steel ball valve to be installed as indicated on the plans. The valve must have an adjustable stem packing, reinforced PTFE seats, PTFE stem packing, thrust washer and body seal. Pressure rating no less than 1000psi (70 bars) WOG non-shock, 125psi (8.6 bars) WSP. Valve must conform to MSS-SP-110. Valve shall be a Watts Regulator Company Series C-FBV-1.

Pressure – Temperature

Temperature Range: 0°F - 400°F (-18°C – 204°C)

Maximum Working Pressure: 1000psi (70 bars) WOG non-shock; 125psi (8.6 bars) WSP

ISO 9001
CERTIFIED

WATTS[®]
REGULATOR

USA: 815 Chestnut St., No. Andover, MA 01845-6098; www.wattsreg.com

Canada: 5435 North Service Rd., Burlington, ONT L7L 5H7; www.wattscanada.ca

Watts product specifications in U.S. customary units and metric are approximate and are provided for reference only. For precise measurements, please contact Watts Technical Service. Watts reserves the right to change or modify product design, construction, specifications, or materials without prior notice and without incurring any obligation to make such changes and modifications on Watts products previously or subsequently sold.

Materials

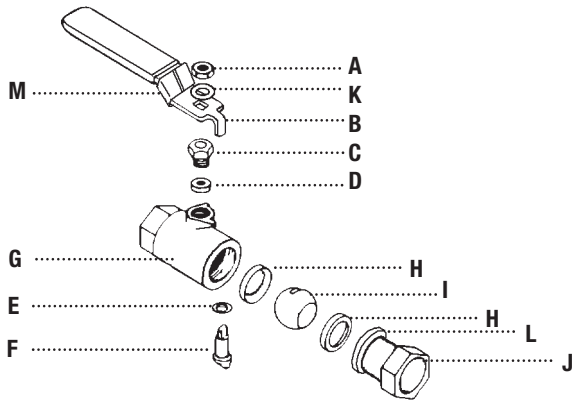

A	Handle Nut	Carbon Steel
B	Handle	AISI 304 with Vinyl Insulator
C	Packing Nut	AISI 304
D	Stem Packing	PTFE
E	Thrust Washer	PTFE
F	Stem	AISI 304
G	Body	ASTM A216 gr.WCB
H	Seats	Reinforced PTFE
I	Ball	AISI 304
J	Adapter	ASTM A216 gr.WCB
K	Lock Washer	Carbon Steel
L	Body Seals	PTFE
M	Latch-Lok	AISI 304

Valve Seat Rating

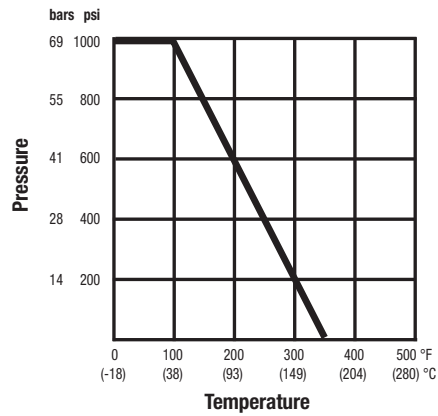

SIZE (DN)		CV	TORQUE	
in.	mm	Rating	in.-lbs.	N - m
1/4"	8	6	36	4.07
3/8"	10	12	36	4.07
1/2"	15	19	43	4.86
3/4"	20	37	65	7.34
1"	25	64	102	11.53
1 1/4"	32	103	160	18.08
1 1/2"	40	143	188	21.24
2"	50	360	340	25.99
2 1/2"	65	440	430	48.59
3"	80	520	780	88.06

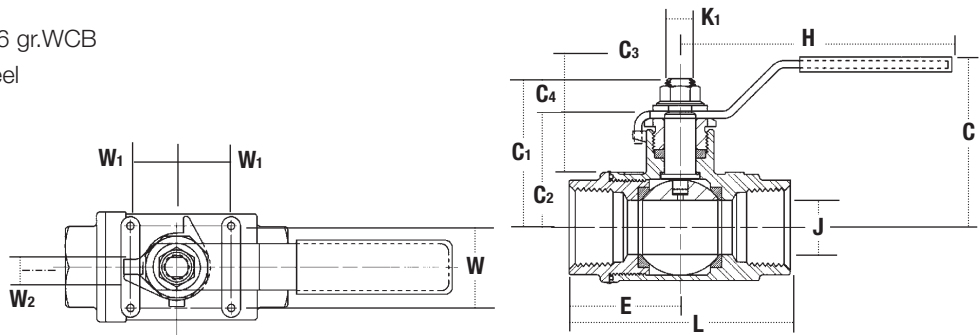

Dimensions – Weights

SIZE (DN)		DIMENSIONS								WEIGHT					
		C Center to Handle		C1 Stem Top		C2 Bottom of Stem Flat		C3 Mounting Pad to Stem Top		C4 Stem Flat Height		E Center to End		H Radius to Handle	
in.	mm	in.	mm	in.	mm	in.	mm	in.	mm	in.	mm	in.	mm	in.	mm
1/4	8	1 3/4	44	1 1/16	40	1	25	7/8	22	9/16	14	1 1/16	27	3 15/16	100
3/8	10	1 3/4	44	1 1/16	40	1	25	7/8	22	9/16	14	1 1/16	27	3 15/16	100
1/2	15	2	51	1 3/4	44	1 3/16	30	1 1/8	29	9/16	14	1 3/16	30	4 1/2	114
3/4	20	2	51	2	51	1 3/8	35	1 1/8	29	9/16	14	1 5/16	33	4 1/2	114
1	25	2 1/2	64	2 1/4	57	1 11/16	43	1 5/16	33	5/8	16	1 3/8	41	4 9/16	125
1 1/4	32	2 3/4	70	2 1/2	64	1 7/8	48	1 5/16	33	5/8	16	1 3/4	44	4 9/16	125
1 1/2	40	3 1/16	84	3	76	2 1/8	54	1 9/16	40	7/8	22	2 1/4	57	6 5/16	160
2	50	3 5/8	92	3 3/4	83	2 1/2	64	1 5/8	41	3/4	19	2 1/2	64	6 5/16	160
2 1/2	65	4 1/2	114	4 1/2	114	3 5/16	84	2 1/8	54	1 1/4	32	3 1/4	83	9 1/16	230
3	80	4 15/16	125	4 15/16	125	3 3/4	95	2 1/8	54	1 3/16	30	3 1/2	89	9 1/16	230

SIZE (DN)		DIMENSIONS								WEIGHT					
		J Ball Orifice		K1 Stem Diameter		L End to End		W		W1		W2 Across Flats		lbs.	kg.
in.	mm	in.	mm	in.	mm	in.	mm	in.	mm	in.	mm	in.	mm		
1/4	8	1/4	6	5/16	8	2 1/16	52	1 1/8	28	1/2	13	3/16	5	.68	.31
3/8	10	3/8	10	5/16	8	2 1/16	52	1 1/8	28	1/2	13	3/16	5	.68	.31
1/2	15	1/2	13	3/8	9	2 3/8	60	1 1/8	28	1/2	13	1/4	7	.90	.41
3/4	20	3/4	19	3/8	9	2 5/8	67	1 3/8	35	7/8	22	1/4	7	1.39	.63
1	25	1	25	7/16	11	3 1/4	83	1 3/8	35	7/8	22	5/16	8	1.98	.90
1 1/4	32	1 1/4	32	7/16	11	3 3/8	92	1 1/2	38	1 5/16	24	5/16	8	3.21	1.48
1 1/2	40	1 1/2	38	5/8	15	4 3/8	111	1 1/2	38	1 5/16	24	3/8	10	4.50	2.04
2	50	2	51	5/8	15	4 9/16	125	1 1/2	38	1 5/16	24	3/8	10	7.17	3.25
2 1/2	65	2 1/2	64	3/4	19	6 1/16	164	2 1/16	55	1 3/8	35	1/2	13	15.4	7.0
3	80	3	76	3/4	19	6 7/16	164	2 1/16	55	1 3/8	35	1/2	13	21.17	9.6